



## TJERNLUND PRODUCTS, INC.

1601 Ninth Street • White Bear Lake, MN 55110-6794  
 PHONE (800) 255-4208 • (651) 426-2993 • FAX (651) 426-9547  
 Visit our web site • www.tjernlund.com



# MODEL MPC1 MODULATING PRESSURE CONTROL INTERLOCK INSTALLATION INSTRUCTIONS

 Recognize this symbol as an indication of important Safety Information!

### OWNER INSTRUCTIONS, DO NOT DESTROY

#### WARNING

THESE INSTRUCTIONS ARE INTENDED AS AN AID TO QUALIFIED, LICENSED SERVICE PERSONNEL FOR PROPER INSTALLATION, ADJUSTMENT AND OPERATION OF THIS PRODUCT. READ THESE INSTRUCTIONS THOROUGHLY BEFORE ATTEMPTING INSTALLATION OR OPERATION. FAILURE TO FOLLOW THESE INSTRUCTIONS MAY RESULT IN IMPROPER INSTALLATION, ADJUSTMENT, SERVICE OR MAINTENANCE POSSIBLY RESULTING IN FIRE, ELECTRICAL SHOCK, CARBON MONOXIDE POISONING, EXPLOSION, PERSONAL INJURY OR PROPERTY DAMAGE.

**DO NOT DESTROY. PLEASE READ CAREFULLY AND  
 KEEP IN A SAFE PLACE FOR FUTURE REFERENCE.**

## TABLE OF CONTENTS

	Page (s)
MPCI Modulating Pressure Control Description .....	1
Installation Restrictions.....	1
Cautions .....	1
Sample and Reference Pressure Connections .....	2
Pressure Sensing Tube Locations & Installation.....	2-4
Make-up / Combustion Air Pressure Set Point .....	5
MPCI Sequence of Operation.....	5
Wiring .....	5-11
MPCI Operation Confirmation .....	11
Adjusting Draft and Balancing Draft of Heaters.....	12
Changing MPCI Pressure Control Program Defaults .....	12-13
Warranty and Replacement Parts .....	13-14

Tjernlund Products welcomes your comments and questions. Address all correspondence to:  
Customer Service • Tjernlund Products, Inc. • 1601 Ninth Street • White Bear Lake, MN 55110-6794  
Call us toll free at 800-255-4208, visit our web site @ [www.tjernlund.com](http://www.tjernlund.com) or email us at [fanmail@tjfans.com](mailto:fanmail@tjfans.com).

## DESCRIPTION

The MPCI Controller (with integral UC1 burner interlock) is designed to modulate draft, exhaust or supply air so that the programmed pressure set point is maintained. The model MPCI (with burner interlock) must be installed if used to exhaust or provide combustion air for fuel burning equipment. Two MPCI Controllers will be needed if controlling both exhaust and supply air. Interlocked burners will only operate when the pressure set point is obtained and will be disrupted if the pressures fall below the set point for a timed period.

### FOR EXHAUST APPLICATIONS:

Pressure is measured in a chase, duct or vent at the farthest point from the Exhaust Fan. As exhaust volume increases within the duct/chase/vent the resulting reduction in measured pressure causes the controller to speed the fan up to handle the additional exhaust volume and slow the fan down when the exhaust volume is reduced to maintain a consistent exhaust pressure.

### FOR SUPPLY / MAKE-UP AIR APPLICATIONS:

Pressure is measured within a mechanical room space or duct connected to the outdoor air supply fan. As air is exhausted from the monitored space the controller modulates the supply air fan speed to maintain the pressure set point air pressure within the space or duct.

## GENERAL INFORMATION

Each MPCI Controller is electrically factory line tested before shipment. After opening carton, inspect thoroughly for hidden damage. If any damage is found notify freight carrier and your distributor immediately and file a concealed damage claim.

## INSTALLATION RESTRICTIONS

1. **Do not** use the MPCI with gas or oil fired heating equipment without interlocking all burners being served with the integral UC1 Control and the required number of MAC-Series Multiple Appliance Controls. Follow instructions and wiring diagrams included and perform "Operation and Interlock Confirmation" check on Page 11 to validate the interlock is operating correctly.
2. The MPCI Controller is intended for indoor installation only. Do not mount on a heat source or in an environment that exceeds 122°F (50°C) or 85% relative humidity.
3. The maximum wire distance from the Control to a VFD or ECM Exhaust Fan Motor is 300 feet. Install the MPCI as close to the pressure sampling point as possible to avoid delayed response to pressure changes. Do not exceed a sampling tube length of 15 feet (6 feet included with PSA-1 Fan Prover). The default fan acceleration rate may need to be increased for sampling tube lengths greater than 10 feet.

## CAUTIONS

The MPCI controller must be installed by a qualified installer (an individual properly licensed and/or trained) in accordance with all local codes or, in their absence, in accordance with the National Electrical Code, Uniform Mechanical Code and International Fuel Gas Code if applicable. Failure to install, maintain and/or operate the MPCI Controller in accordance with manufacturer's instructions may result in conditions which can produce bodily injury and property damage.

1. Disrupt external supply power to MPCI Controller when making wiring connections and servicing. Failure to do so may result in personal injury and/or equipment damage.
2. All installation restrictions and instructions specific to the exhaust or supply Fan installation instructions must be followed.
3. Make certain the power source is adequate for the MPCI requirements. Do not add equipment to a circuit when the total electrical load is unknown.

## SAMPLE AND REFERENCE PRESSURE CONNECTIONS

<u>Application</u>	<u>Sensing Tube Sample Location</u>	<u>MPCI Pressure Port</u>	<u>Reference Pressure Location</u>	<u>MPCI Pressure Port</u>
Exhaust	Bottom of Chase	Connect to Negative (-)	Room at Bottom of Chase	Positive (Port Open)
Draft	Rear of Manifold	Connect to Negative (-)	Heater Mechanical Room	Positive (Port Open)
Open Supply	Mechanical Room	Positive (Port Open)	Adjacent Room	Connect to Negative (-)
Sealed Supply	End of Supply Duct	Connect to Positive (+)	Heater Mechanical Room	Negative (Port Open)

Recommendations based on MPCI Control being installed in the same room as the sample location. If the MPCI is installed in an adjacent space, pneumatic connections must be made to the open Pressure Ports that are indicated above.

## PRESSURE SENSING TUBE INSTALLATION LOCATIONS

### FOR MECHANICAL DRAFT INSTALLATIONS

The Pressure Sensing Tube should be installed in the cap of a tee or rear of a common manifold. The tee is necessary so that only static pressure is measured. If the transducer sensing tube is installed in the side of a vent pipe it will also measure velocity pressure, giving an incorrect signal back to the Pressure Control. If mounting on the side of the pipe is unavoidable, the sensing tube should be flush to the interior wall of the vent pipe. Typically, draft applications should sample at a point in back of the vent connection that is farthest from the exhaust fan, (See Figure A).

FIGURE A

IF POSSIBLE, THE SENSING TUBE SHOULD BE LOCATED TWICE THE MANIFOLD DIAMETER BEHIND THE HEATER FURTHEST FROM INDUCER.

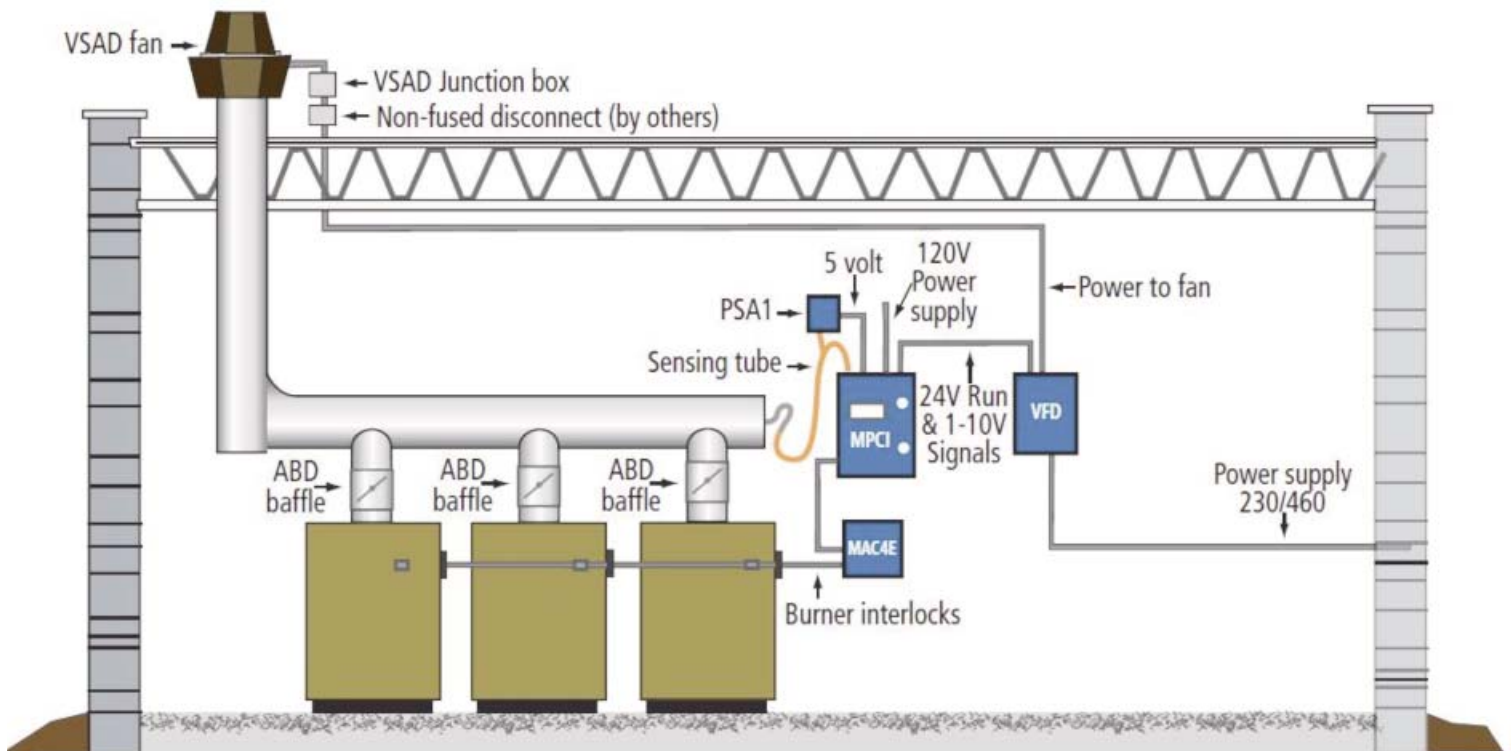
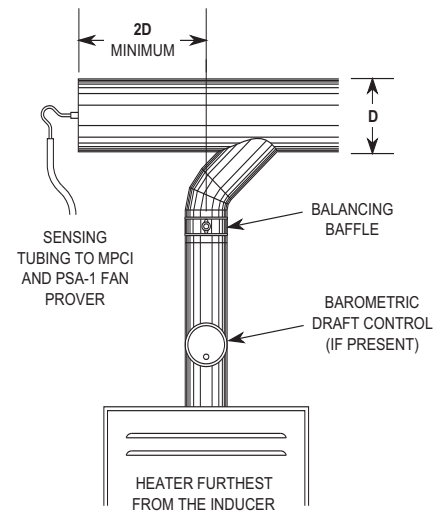

**FOR “SEALED” MAKE-UP AIR APPLICATIONS**

The Pressure Sensing Tube should be installed in the capped end of a common supply manifold. This is necessary so that only static pressure is measured. If the transducer sensing tube is installed in the side of a duct it will also measure velocity pressure, giving an incorrect signal back to the Pressure Control. If mounting on the side of the duct pipe is unavoidable, the sensing tube should be flush to the interior wall of the duct. If a filter is installed it must be positioned between the blower inlet and intake opening.

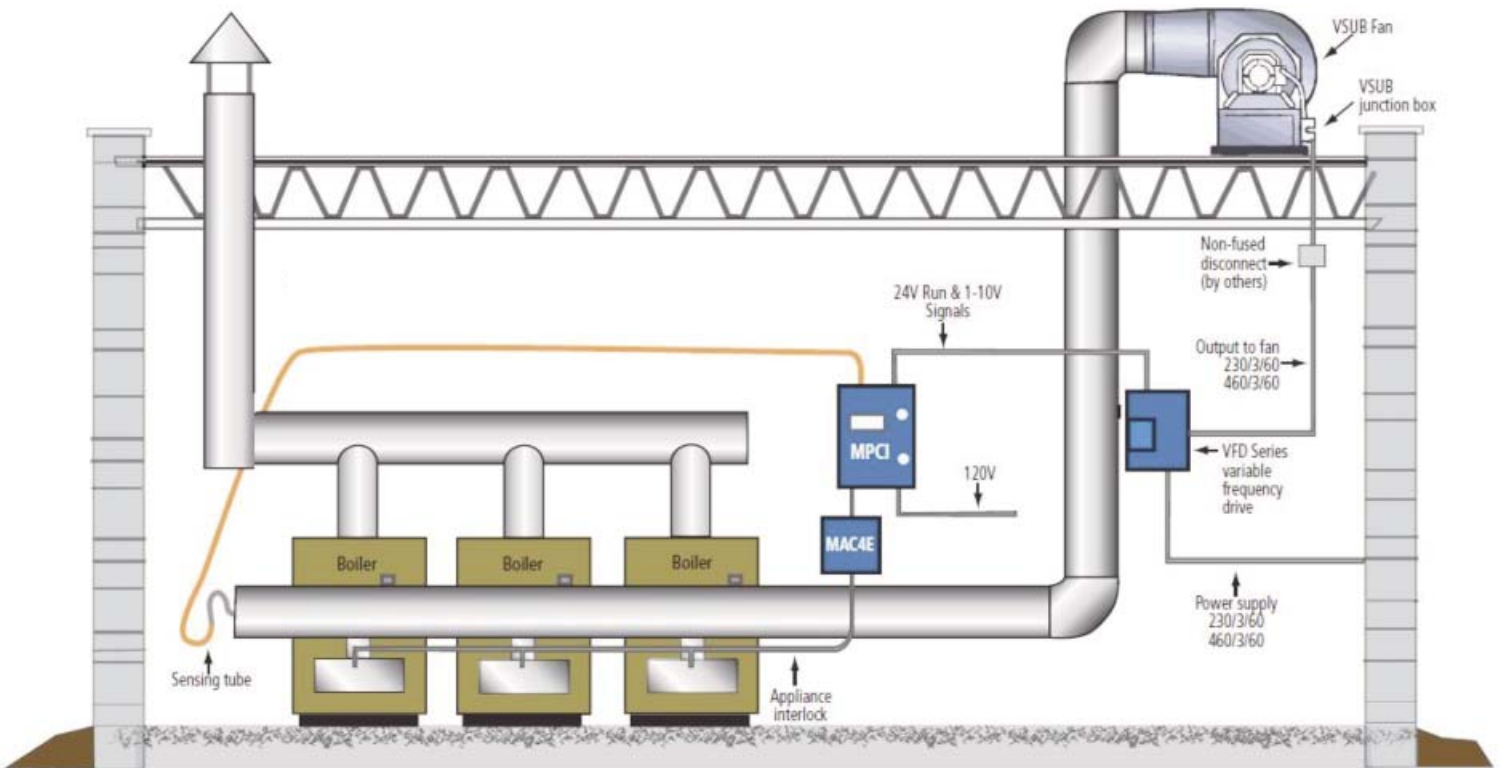

**FOR “OPEN” MAKE-UP AIR APPLICATIONS**

In "Open" mode the mechanical room air is sampled and an adjacent space is referenced. Referencing an adjacent space within the building typically provides a more stable reference pressure than referencing outdoor air. Varying wind speeds will affect outdoor reference pressure and are difficult to neutralize. The goal is to reference static pressure. Don't sample pressures at locations that can be affected by frequently opened doors, elevator shafts, ventilation fans and diffusers. The model IPS-1 adjacent space Reference Pressure Sensor includes a decorative cover, sampling tube and fittings may be used in conjunction with the MPC1

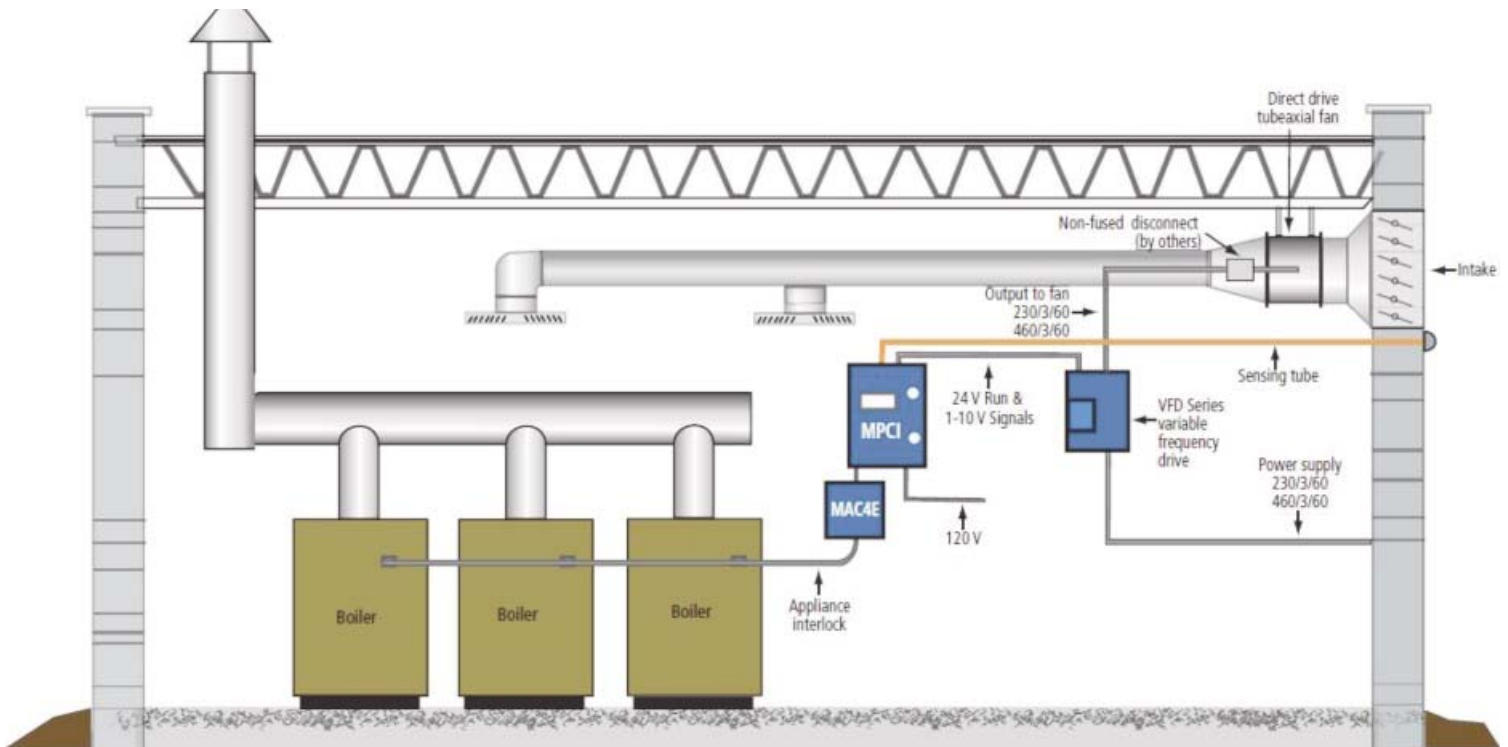

## PRESSURE SENSING TUBE INSTALLATION

1. Follow sensing tube installation location recommendations. Use a sharp drill bit to reduce burr, drill a 1/4" hole for pressure sensing tube. Screw sensing tube bracket to duct/chase with sampling hole centered, (See Figure B).
2. Insert stainless steel sensing tube through 1/4" hole enough to just penetrate interior of duct/chase and lock in place with compression ferrule and nut, (See Figure B).
3. Connect sampling tube with included tubing to the correct pressure port on the exterior of the MPCl enclosure. The Pressure Ports are located on the Top Right side of the MPCl Cabinet. These are the pneumatic connection points to the Pressure Control inside the MPCl. The Rear Port (-) is for those applications where a negative pressure is required. This port is typically used for Exhaust applications. The Front Port (+) is typically for those supply air applications where a neutral or positive pressure is required. See "Sample and Reference Connections", Page 2 for port information. For rear Negative (-) and front Positive (+) port location on MPCl, (See Figure C). **Important:** Excessive additional lengths of tubing will delay the response of the Fan which can lead to control lag.

FIGURE B

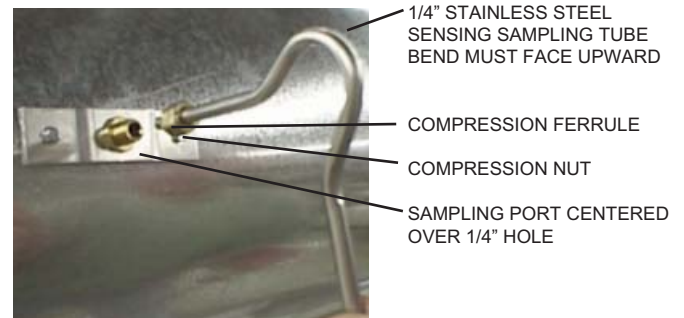
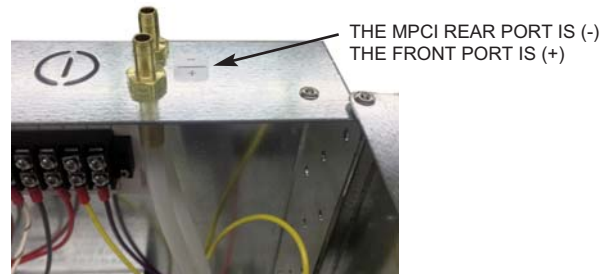

FIGURE C



## PSA-1 PRESSURE SWITCH & PNEUMATIC TUBING INSTALLATION FOR INTERLOCKED EXHAUST APPLICATIONS

**Do not** use the PSA-1 Pressure Switch for Supply/Combustion Air Applications. Pressure Control set point is outside of the PSA-1 operating range.

1. Mount the PSA-1 Pressure Switch within 6 feet of the sensing tube location. The switch must be mounted in a vertical position so that the sampling tube connections are on the bottom of the switch body. Turn the adjustment screw on the PSA-1 pressure switch counter-clockwise until it stops.
2. Connect a short length of tubing to the stainless steel sensing sampling tube.
3. Insert one end of the plastic T fitting included with the MPCl sampling tube packet into the end of the tubing installed in step 2.
4. Connect tubing to one of the remaining T connections and to the 1/4" tubing snub of the **LOW** port of the PSA-1 Pressure Switch. Tighten compression nut.
5. Using the remaining flexible tubing connect the remaining open T to the barbed port on the top, rear pressure port on the exterior of the MPCl enclosure. The Pressure Ports are located on the Top Right side of the MPCl Cabinet. These are the pneumatic connection points to the Pressure Control inside the MPCl. The Rear Port (-) is for those applications where a negative pressure is required. This port is typically used for Exhaust applications, (See Figure D). See "Sample and Reference Connections", Page 2 for port information. Excessive additional lengths of tubing will delay the response of the Fan which can lead to control lag.

FIGURE D

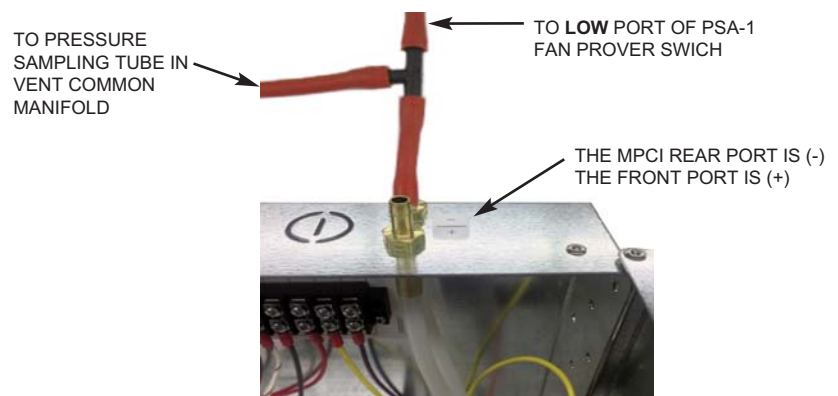

## WIRING

The MPC1 must be wired by a qualified installer (an individual properly licensed and/or trained) in accordance with these instructions and in accordance with all local codes or in their absence, with the current editions of NFPA 70, National Electrical Code in the U.S. or CSA C22.1-12 Canadian Electrical Code in Canada.

All 120 V wiring from the MPC1 to the Fan junction box must be appropriate Class 1 wiring as follows: installed in rigid metal conduit, intermediate metal conduit, rigid non-metallic conduit, electrical metallic tubing, Type MI Cable, Type MC Cable, or be otherwise suitably protected from physical damage.

The maximum distance the 1-10 VDC output from the MPC1 to the VFD or ECM motor is 300 feet. Exceeding this distance can result in lower than desired signal strength. 1-10 VDC wiring should be in metal conduit or utilize shielded cable. Non-shielded signal wiring can be influenced by outside conditions resulting in undesirable operation of the MPC1 control.

### IMPORTANT:

Installer must supply overload and disconnect protection as dictated by local and national codes. Do not use a fused disconnect. MPC1 Control supply power may be switched through a building management system, pressure switch or other 120 VAC switch.

### IMPORTANT:

#### MOTOR ROTATION **MUST** BE VERIFIED PRIOR TO OPERATION CHECKS.

If using the model MPC1 in conjunction with a VFD, fan rotation must be checked to validate that the motor is turning in the correct direction. Fans should have rotation stickers on the housing or motor mount. Activate the MPC1 as directed below and then disrupt operation so that motor rotation can be detected as the motor coasts down. If rotation is incorrect, change by switching any two of the 3 power output leads from the VFD to the fan motor. Verify proper rotation by repeating steps above.

## SUPPLY MAKE-UP / COMBUSTION AIR PRESSURE SET POINT

MPC1 Controllers are defaulted to a 0.10" w.c. set point. To enable the SET POINT 2, default setting (0.00" w.c.) for Supply Make-up / Combustion air, a jumper wire must be installed between terminals 8 & 9 on the right hand side of the Pressure Control terminal strip, (See Figure E). Remove Pressure Control cover with small phillips screwdriver to access terminal strip.



FIGURE E

JUMPER WIRE MUST BE INSTALLED ON PRESSURE CONTROL BETWEEN TERMINALS 8 & 9 TO ENABLE SET POINT 2.

## MPC1 SEQUENCE OF OPERATION

An intercepted call for heat is sensed at terminals A & B or 1 & 2 of the integral UC1 Interlock Control or MAC-Series interlock expansion modules. The Amber LED of the UC1 will turn on.

1. This closes the motor relay of the UC1 sending 120 V to the MTR terminal of the Power Terminal Block (can be used to power 120 VAC intake damper motors up to 5 amps or energize the coil of a line voltage VFD activation relay). The Green LED on the UC1 will turn on.
2. Simultaneously it energizes the 24 VAC transformer to supply power to:

The 24 VAC hot of the external Green run light on the MPC1 cover.

Terminal 5 of the Pressure Control to power the common of its N/O alarm relay contacts.

The 24 terminal of the Pressure Control Terminal Block. (Used to energize Tjernlund Products VFDxxx-MPC Series VFD activation relay within VFD electrical enclosure)

Terminal 1 of the Pressure Control, activating it to measure system pressure and to output a proportional 1-10 VDC signal to the 1-10 terminal of the Control Terminal Strip. The 1-10 VDC signal from the Control Terminal Strip is wired directly to an ECM motor input or to a VFD input to vary the fan speed to maintain the set point as volume, stack effect, wind loading and reference pressure change.

As long as the pressure set point is made within 10 seconds (field adjustable) of the pressure control producing 10 VDC (max. output) and the PSA-1 Fan Prover is closed, the UC1 interlock control will complete the circuit to the burner(s) through terminal 4 of its terminal strip. The Blue LED on the UC1 will turn on. **IMPORTANT:** The PSA-1 Fan Prover is not used for Supply / Make-Up air applications since its operating range is outside of the 0.00" w.c. set point of the Pressure Controller.

When the call(s) for heat is satisfied the circuit from terminal 4 of the UC1 to the burner(s) is disrupted and the UC1 starts its post purge cycle. Red LED's 4 & 5 of the UC1 will flash in unison during post purge. The Pressure Control will maintain set-point for a 2-minute post purge cycle and then disrupt 120 VAC power from the MTR terminal of the UC1, powering off the 24 VAC transformer and shutting off the Pressure Control, Green run light and the 24 VAC output from the Control terminal strip. Red LED 6 on UC1 will stay lit and Red LED 5 will blink on and off every 3 seconds until a call for heat is sensed.

# MPCI WIRING

Modulating Pressure Control Interlocked

Electrical Specifications

Power supply: 120 VAC, 7 amps minimum  
 Switch: 120 VAC, 7 amps minimum  
 Run: 120 VAC, 5 amps out maximum

Prover: 1 amp at 120 VAC  
 Alarm: 10 amps at 120 VAC  
 Control: 20 VA maximum out



# TJERNLUND

Draft • Combustion Air • Ventilation  
 800.255.4208 www.tjernlund.com



Intertek

LEGEND

---	= 5 VDC
—	= 24 VAC
—	= 115 VAC

Maximum ambient temperature for this control is 122° F (50° C).  
 Field conductors are to be copper (Cu) only and to be rated 140° F (60° C) or higher.  
 Torque the large terminal block screws to 10 lb-in.  
 Torque the small terminal block screws located on 9183006 (the UC1 Controller) to 7 lb-in.

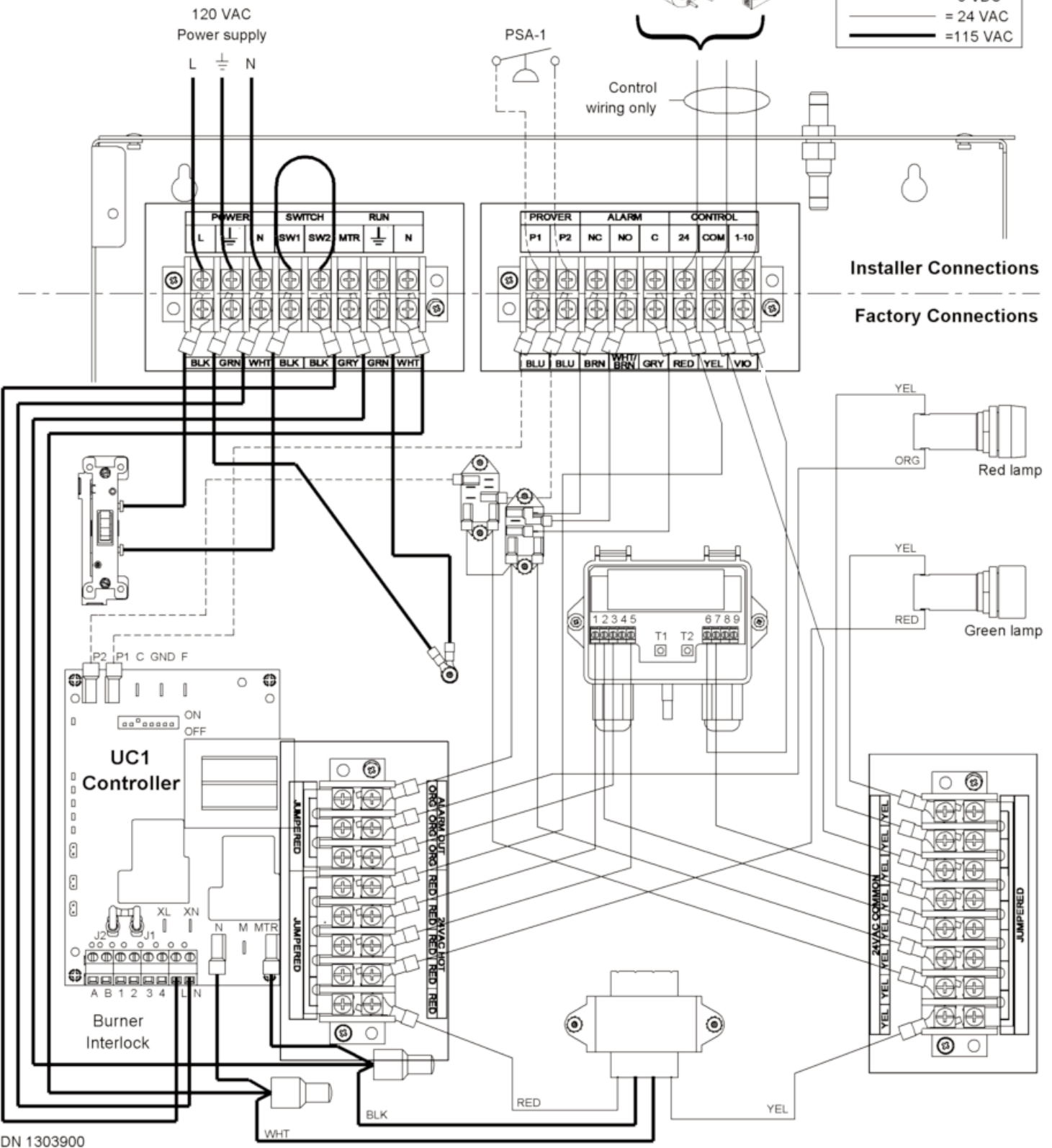
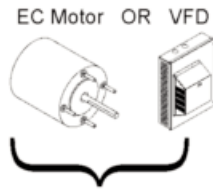

## PRESSURE FAULT SEQUENCE

If either the alarm circuit of the Pressure Control closes or the PSA-1 fan prover opens for more than 10 seconds, the UC1 interlock control will disrupt the circuit from terminal 4 to the burner(s). The MPC1 external Red fault light with audible alarm will come on and sound alarm. The auxiliary alarm contacts will change state. Red LED 4 on the UC1 will flash continuously.

The Pressure Control will continue to try to obtain the set point for 10 minutes. If the alarm circuit opens and the PSA-1 fan prover closes during this 10-minute period, the UC1 interlock will automatically reset and complete the circuit to the burner(s). The UC1 interlock will go into a hard lockout after 10 minutes without an automatic reset. Disrupting the call for heat or shutting off the MPC1 internal 120 VAC power switch for 10 seconds will reset the UC1 interlock control.

## MPCI BURNER INTERLOCK FEATURING THE UC1

The UC1 is the standard interlock control for Tjernlund's full line of Power Venters, Draft Inducers and Combustion Air fans. It can be interlocked with virtually any burner control circuit. Features include: adjustable pre & post purge, LED status / diagnostic indicators, 10 second prover switch delay to avoid burner start up and wind induced short cycling. Interlocks with any 24-115 VAC burner control circuit and also includes "dry" contact actuation option. After each burner cycle, the UC1 will continue to operate in post-purge mode to allow the fan to purge the heater and vent of residual flue gases. A factory post-purge time is set at 2 minutes and is adjustable up to 16 minutes, see "Pre / Post Purge and Prover Status Check Dip Switch Settings" on page 9.

1. The UC1 Pre-Cycle Prover Status Check is deactivated from the factory to avoid nuisance lock out in applications where exhaust shafts or vents may be capable of creating enough chimney effect to make the pressure set point prior to a call for heat. When activated, the UC1 Universal Control checks across the P1 & P2 safety circuit Fan Prover to verify that the Fan Prover switch is "Open" upon a call for heat and not stuck "Closed". See "Pre-Cycle Fan Prover Status Check", page 9 for details.
2. A post-purge on the UC1 has been factory set at 2 minutes. Confirm that dip switch #5 is in the up or "on" position. A longer post-purge may be necessary for longer vent runs or high heat retention, refractory lined combustion chambers. A shorter post-purge may be desired for short vent lengths. If using the UC1 to control a combustion air fan a post-purge may not be desired. See "Pre / Post Purge and Prover Status Check Dip Switch Settings", page 9 for details.

## CAUTIONS

Disrupt supply power to the MPC1 and heating equipment when making wiring connections and servicing the UC1 Control. Failure to do so may result in personal injury and/or equipment damage. UC1 LED #6 (Red) should be off with power removed.

All installation restrictions and instructions in the Exhaust/Supply Air Fan and/or VFD installation instructions must be adhered to.



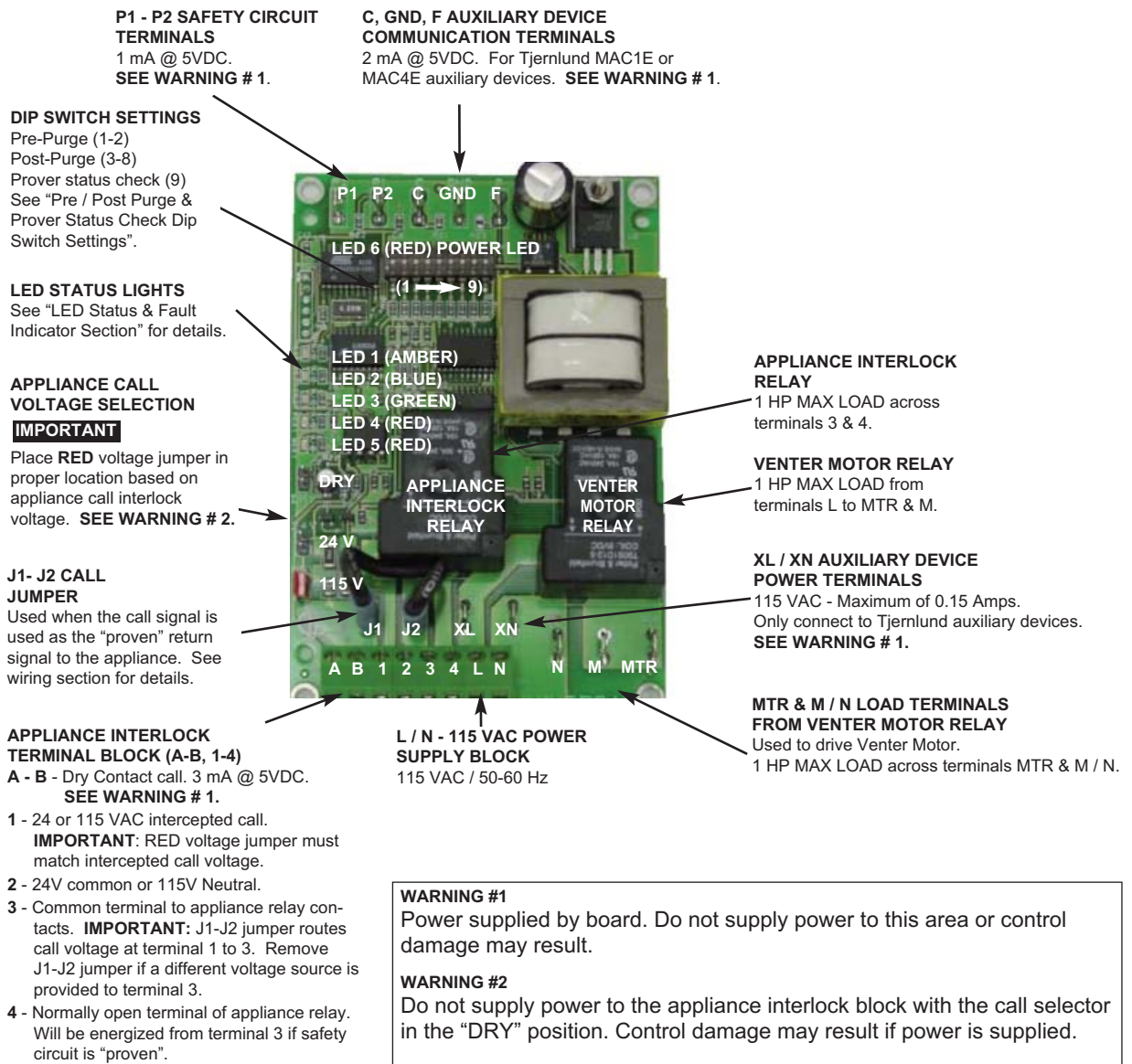

## LED INDICATOR LIGHTS

- LED #1 (Amber) Appliance call for heat.
- LED #2 (Blue) Safety circuit through P1 & P2 (Venter Fan Prover and/or Limit). Indicates Venter prover is closed during run cycle. Burner circuit is energized with Interlock Relay contact closure from terminal 3 to 4.
- LED #3 (Green) Power switched to Venter motor from L to MTR & M.
- LED #4 (Red) Status / Fault indicator.
- LED #5 (Red) Used as a status indicator.
- LED #6 (Red) 115 VAC power supplied to board.

## LED STATUS INDICATORS

- LED #4 & #5 (Red) Flashing Alternately = Venter in Pre-purge. (Pre-Purge options 0, 5, 20, 35 seconds)
- LED #4 & #5 (Red) Flashing in Unison = Venter in Post-Purge. (Post-Purge options 0, 30 seconds or 1, 2, 4, 8, 16 minutes)
- LED #4 Flashes Continuously\* = Fan Prover opened for more than 10 seconds during burner cycle.  
(Venter will run for 10 minutes, attempting to make Fan Prover)
- LED #5 (Red) Flashing Intermittently = With no call for heat, flashes 3 seconds on / 3 seconds off if microcontroller is working properly.

## LED FAULT INDICATORS

Fault conditions are indicated by counting the number of times LED #4 (Red) flashes.

- LED #4 Flashes 2 Times Fan Prover was in electrically closed position prior to venter operation.
- LED #4 Flashes 3 Times\* Fan Prover does not close within 60 seconds after call for heat.
- LED #4 Flashes 4 Times\* Fan Prover did not re-close after 10 minutes of Venter operation.
- LED #4 Flashes 5 Times\* Fan Prover opened for more than 10 seconds during burner cycle but closed within 10 minutes.

\* Investigate cause of Fan Prover short cycling such as; Firing burner at capacities or temperatures exceeding Venter limits, excessive vent pipe runs, elbows directly on venter discharge, high winds, plugged / kinked Fan Prover sensing tube or a faulty PSA-1 Fan Prover switch.

**IMPORTANT:** UC1 Fault codes will automatically be displayed after a fault condition occurs. If the call for heat interlock signal or 115 VAC power is removed, the UC1 board will reset and the fault will be stored in memory instead of displayed. Any new fault will replace any previous fault.

**CHECKING MEMORY FOR LAST FAULT CODE**

**IMPORTANT:** Prior to accessing the fault code memory, note the settings of the dip switches so that they can be returned to their original Pre / Post-Purge positions. When power is supplied to the UC1 use caution when moving dip switches.

The last fault code can be retrieved at any time by setting all dip switches 1-8 to the up, or “on” position. The last fault code, or lack there of, will be indicated by counting the number of times LED 4 flashes. By moving any of the dip switches back to their original position, the fault code will be cleared. **NOTE:** The UC1 board must have its 115 VAC power supply present when any of the (1-8) dip switches are moved back to their original position for the fault code to clear.

**PRE / POST PURGE AND PROVER STATUS CHECK DIP SWITCH SETTINGS**

**DIP SWITCH NUMBERING**

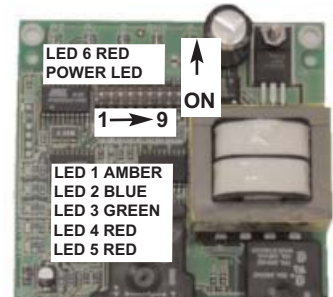
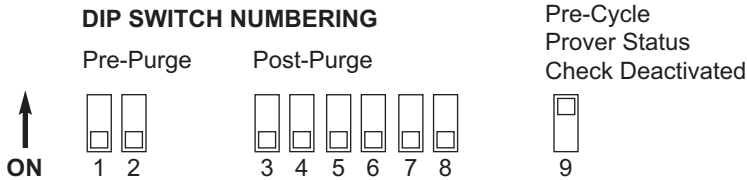

**POST-PURGE SETTINGS (SEE “POST-PURGE” ABOVE PRIOR TO SETTING)**

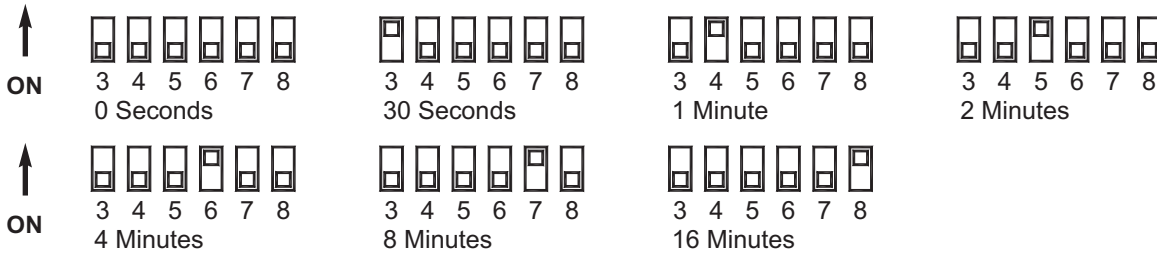

**PRE-PURGE SETTINGS (SEE “PRE-PURGE” ON PAGE 3 PRIOR TO SETTING)**

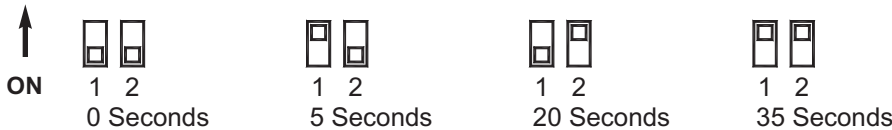

**P1 & P2 PRE-CYCLE FAN PROVER STATUS CHECK**

Pre-Cycle Prover Status Check Deactivated  9 The UC1 Pre-Cycle Prover Status Check is deactivated from the factory to avoid nuisance lockouts in applications where exhaust shafts or vents may be capable of creating enough chimney effect to make the pressure set point prior to a call for heat. When activated, the UC1 Universal Control checks across the P1 & P2 safety circuit Fan Prover to verify that the Fan Prover switch is “Open” upon a call for heat and not stuck “Closed”. Keeping the Prover Status Check activated may cause nuisance lockouts. Push up or “ON” to deactivate.

All wiring from the UC1 to the appliance must be appropriate Class 1 wiring as follows: installed in rigid metal conduit, intermediate metal conduit, rigid non-metallic conduit, electrical metallic tubing, Type MI Cable, Type MC Cable, or be otherwise suitably protected from physical damage.

The "1" input terminal on the UC1 can accept either a 24 VAC or 115 VAC control signal. **IMPORTANT:** The RED voltage jumper must be positioned based on appliance interlock voltage 24V or 115V. If using the "DRY" contact activation method, use terminals A & B on UC1 control and position the RED voltage jumper tab in the "DRY" position. See millivolt appliance interlock diagram for further information. **IMPORTANT:** Only one interlock method (i.e. 24V, 115V or "Dry") can be used with the UC1. Multiple appliance interlocks require the use of our MAC-Series multiple appliance controls.

The steps listed under each diagram are intended as a supplement to the diagram. Wiring colors or designations may vary by manufacturer. If you are unable to wire the UC1 as outlined in these instructions, call Tjernlund's Customer Service Department toll free at 1-800-255-4208 for assistance.

**INTEGRAL UC1 ELECTRICAL SPECIFICATIONS**

POWER REQUIREMENTS	T-BLOCK L / N	120 VAC ±10 %, 50/60 Hz CIRCUIT PROTECTION PROVIDED BY INSTALLER
ADD VENTER MOTOR LOAD PLUS 1/2 AMP FOR UC1 LOAD	XL / XN	150 mA MAX @ 120 VAC, 50/60 Hz CAN ONLY BE CONNECTED TO TJERNLUND-SPECIFIED AUXILIARY DEVICE
	UC1 CONTROL	DURING OPERATION THE CONTROL USES 50 mA MAX @ 120 VAC
	M & MTR (RELAY K2)	MOTOR - 1 H.P. MAX. @ 120 VAC, 50/60 Hz GENERAL PURPOSE - 15A @ 120 VAC, 50/60 Hz
EXTERNAL POWER SWITCHING CAPACITY	T-BLOCK 3 TO 4 (RELAY K1)	MOTOR - 1 H.P. MAX. @ 120 VAC, 50/60 Hz GENERAL PURPOSE - 15A @ 120 VAC, 50/60 Hz RESISTIVE - 10A @ 28 VDC PILOT DUTY - 470 VA
EXTERNAL CALL TRIGGER METHODS	T-BLOCK A / B	USER-PROVIDED CONTACT CLOSURE FROM A TO B. SIZE CONTACT CLOSURE TO HANDLE 3 mA @ 5 VDC. MOVE RED VOLTAGE JUMPER TO "DRY" LOCATION. DO NOT SUPPLY POWER.
	OR 24V 1 / 2	USER-PROVIDED 24 VAC AT TERMINALS 1 & 2. 1 = CALL HOT, 2 = COMMON. CONTROL REQUIRES 5 mA @ 24 VAC TO TRIGGER. MOVE RED VOLTAGE JUMPER TO "24V" LOCATION.
	OR 115V 1 / 2	USER-PROVIDED 115 VAC AT TERMINALS 1 & 2. 1 = CALL LINE, 2 = NEUTRAL. CONTROL REQUIRES 1 mA @ 115 VAC TO TRIGGER. MOVE RED VOLTAGE JUMPER TO "115V" LOCATION.
J1 / J2 JUMPER	J1 / J2	USED TO JUMP CALL HOT (24 VAC) OR CALL LINE (115 VAC) FROM TERMINAL 1 TO TERMINAL 3. REMOVE J1-J2 JUMPER IF A DIFFERENT VOLTAGE SOURCE IS PROVIDED TO TERMINAL 3.
SAFETY CIRCUIT	P1 / P2	CONNECTED TO FAN PROVER. 1 mA @ 5 VDC. DO NOT SUPPLY POWER HERE.

FIG 010270514

**UC1 UNIVERSAL CONTROL CONNECTED TO A GAS OR OIL BURNER WITH AN AQUASTAT**

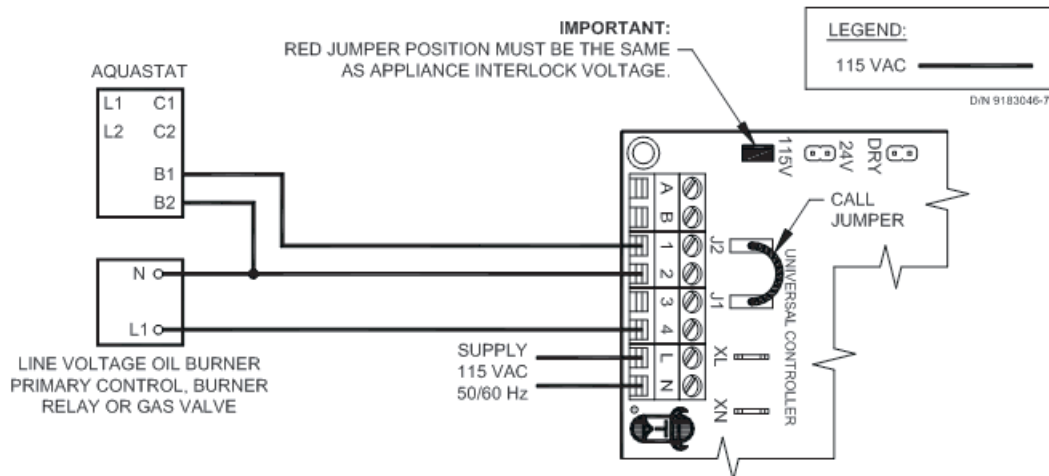

1. Disconnect B1 from L1 of oil burner primary control, burner relay or hot of gas valve and reconnect to #1 on UC1 terminal block.
2. Connect #2 on UC1 terminal block to B2 or N.
3. Connect #4 on UC1 terminal block to the L1 on line voltage oil burner primary control, burner relay or gas valve.
4. Make sure RED voltage jumper on UC1 is on 115V.
5. The PSA-1 Fan Prover is only used for Draft applications, not Combustion Air applications. Wire PSA-1 prover leads to P1 and P2 PROVER terminals in MPC1. Prover leads are non polarity sensitive.

**NOTE:** If burner safety control goes out on lockout, the Venter will continue to run as long as a call for heat is present.

## UC1 / MAC-SERIES CONTROL CONNECTED TO DRY CONTACTS OF BOILER STAGING OR ZONE CONTROL

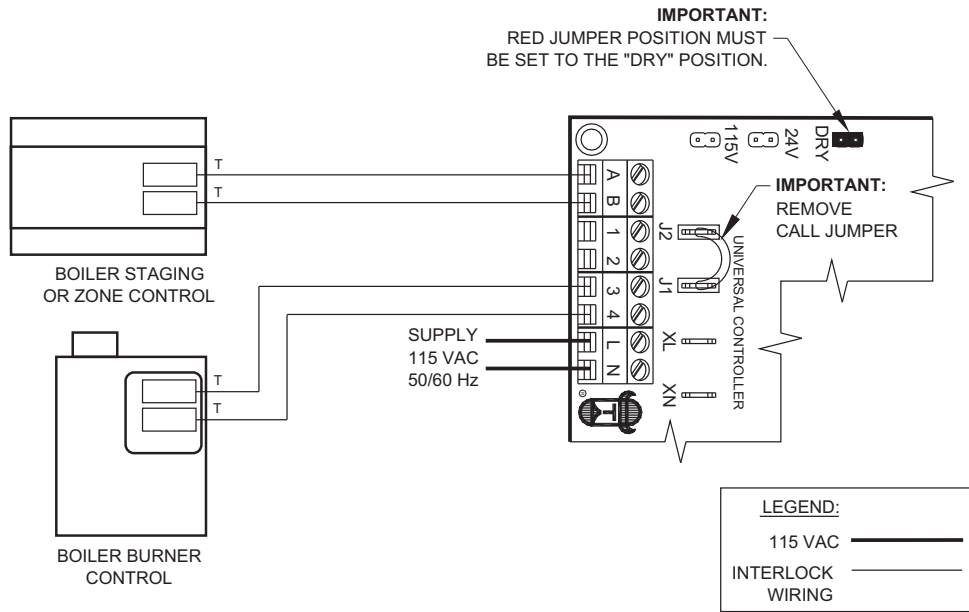

1. Connect TT from staging control to the A & B terminals of the UC1/MAC-Series Interlock associated with that boiler.
2. Connect terminals 3 & 4 of the UC1/MAC-Series Interlock associated with that boiler to the boiler's TT terminals.
3. Move the RED plastic jumper from the 115V pins to the DRY position.
4. **Important:** Remove the call Jumper wire from the J1 & J2 terminals of the UC1 circuit board.  
TT closure of boiler staging or zone control completes the low voltage circuit between A & B of the UC1 / MAC-Series Interlock Controls, activating the Pressure Control. When the Fan Proving switch closes the circuit is completed between terminals 3 & 4, closing the circuit at TT of the boiler's actuation control.
5. The PSA-1 Fan Prover is only used for Draft applications, not Combustion Air applications. Wire PSA-1 prover leads to P1 and P2 PROVER terminals in MPC1. Prover leads are non polarity sensitive.

**NOTE:** If burner safety control goes out on lockout, the Venter will continue to run as long as a call for heat is present.

### MULTIPLE APPLIANCE INTERLOCKS

To interlock with one additional 24/115 VAC heater, add the MAC1E. It is a stripped down auxiliary board version of the UC1 and is powered by and communicates with the UC1 through a factory wired whip.

To interlock more than two 24/115 VAC heaters, add the MAC4E for a total of up to 5 heaters. It is powered by and communicates with the UC1 through a factory wired whip. Consult factory for installations with more than 5 heaters.

### MPCI OPERATION AND INTERLOCK CONFIRMATION

Establish 120 VAC supply power to the MPCI and switch MPCI internal power switch to the ON position.

Activate one of the connected heaters.

Validate that the Status LED's of the UC1 interlock board light and operational sequences occur as described on Page 8.

Remove the pneumatic tubing from the sampling tube to disrupt the connection to the PSA-1 and the MPCI.

After 10 seconds the UC1 interlock control should disrupt the circuit from terminal 4 to the burner(s).

As long as there is a call for heat, the UC1 will continue to power the MPCI Pressure Control for 10 minutes. (If the pressure set point is not reached after 10 minutes, the UC1 will disrupt power to the Pressure Control and go into a hard lockout. Reset UC1 by removing call for heat or turning off the MPCI internal power switch.

The Pressure Control will continue to output a 1-10 VDC signal to speed the fan up.

When the output reaches 10 VDC, a 10 second delay will occur and then the Pressure Control Alarm Circuit will activate, powering the MPCI external RED light with audible alarm as well as any external alarm or BMS that are wired to the alarm circuit.

Reconnect the pneumatic tubing to the sampling tube.

The safety circuit will reset when the pressure set point is once again sensed.

## ADJUSTING DRAFT

Reference the heater manufacturer's instructions for its specified draft range and for where the draft should be sampled. In general, most heaters will operate efficiently with a draft of -0.02 to -0.05" w.c. measured in the vent riser between the flue outlet and barometric draft control (if present). The MPC1 has a default draft set point of -0.10" w.c. This vent manifold pressure may need to be adjusted up or down to meet the draft requirements of the interlocked heating equipment. **Do not** reduce set point to less than 0.07" w.c. to avoid issues with the PSA-1 operating range.

## BALANCING DRAFT OF HEATERS

1. Turn ON the service switch to all of the heaters.
2. Momentarily cycle each heater to verify that the Amber Burner Status Call LED on the UC1 or MAC-Series interlock control illuminates for each heater. If not, verify that wiring conforms to appropriate heater interlock wiring diagram.
3. Verify that all balancing baffles or blast gates are in the closed position. Adjust barometric controls (if present) to the most closed position.
4. Fire each heater individually, starting with the heater farthest from the Exhaust / Supply Air Fan. Slowly open balancing baffle or blast gate until the specified draft is achieved. Barometric draft controls should be closed when the heater is operating within its specified draft range. Adjust weight on barometric draft control so that it does not open until the manufacturer's recommended maximum draft is reached. If additional draft is needed increase the set point on the MPC1.
5. After adjusting draft levels on all connected heaters, fire heaters in random order and simultaneously to verify draft levels remain within the manufacturer's specified range prior to ignition and during operation.

## CHANGING MPC1 PRESSURE CONTROL PROGRAM DEFAULTS

THE FACTORY PRESET PROGRAM SETTINGS ARE AS FOLLOWS:

PROGRAM OPTION	FACTORY PRESETS	ADJUSTMENT RANGE
Pressure Units of Measure	Units InH <sub>2</sub> O	Units PA
Operating Mode	Control Mode	<b>Do Not Change</b>
Parameter	Diff. Pressure	<b>Do Not Change</b>
Setpoint 1 (Use for Draft)	0.10	0 to 40 (PA 0 to 100)*
Setpoint 2 (Use for Supply/Comb Air)	0	0 to 40 (PA 0 to 100)*
* <b>NOTE:</b> A negative value can not be set on the Pressure Control, however, the Pressure Control can display a negative pressure reading. Pressure Control will read either negative or positive pressures depending on what sensing port is used and type of application. See "Sample and Reference Pressure Connections", Page 2.		
Output Voltage	V=10.0 V	<b>Do Not Change</b>
P-Parameter	50	1-999 (Acceleration Rate)
I-Parameter	3.15	<b>Do Not Change</b>
Controlling Mode	Positive/Heating	<b>Do Not Change</b>
Alarm Delay Time	10s	1 Second to 15 Minutes

The MPC1 Pressure Control must be powered to enter the program mode. **WARNING:** Disrupt supply power to MPC1 when removing and reconnecting wire from UC1 MTR terminal. With supply power OFF, remove wire from MTR on the bottom of the integral UC1 Interlock Control and connect to the XL terminal of UC1. Reestablish power to MPC1 and push the Pressure Control left button (T1), make any necessary program changes and cycle through the remaining programs by pushing the T2 button until the display reads MENU. Remove supply power to MPC1 and remove lead from XL on UC1 and reconnect to MTR. Reestablish supply power to MPC1.

To enable the SET POINT 2 for supply/combustion air a jumper wire must be installed between the last two terminals 8 & 9 on the right hand side of the Pressure Control. See "Supply Make-Up / Combustion Air Pressure Set Point", Page 5.

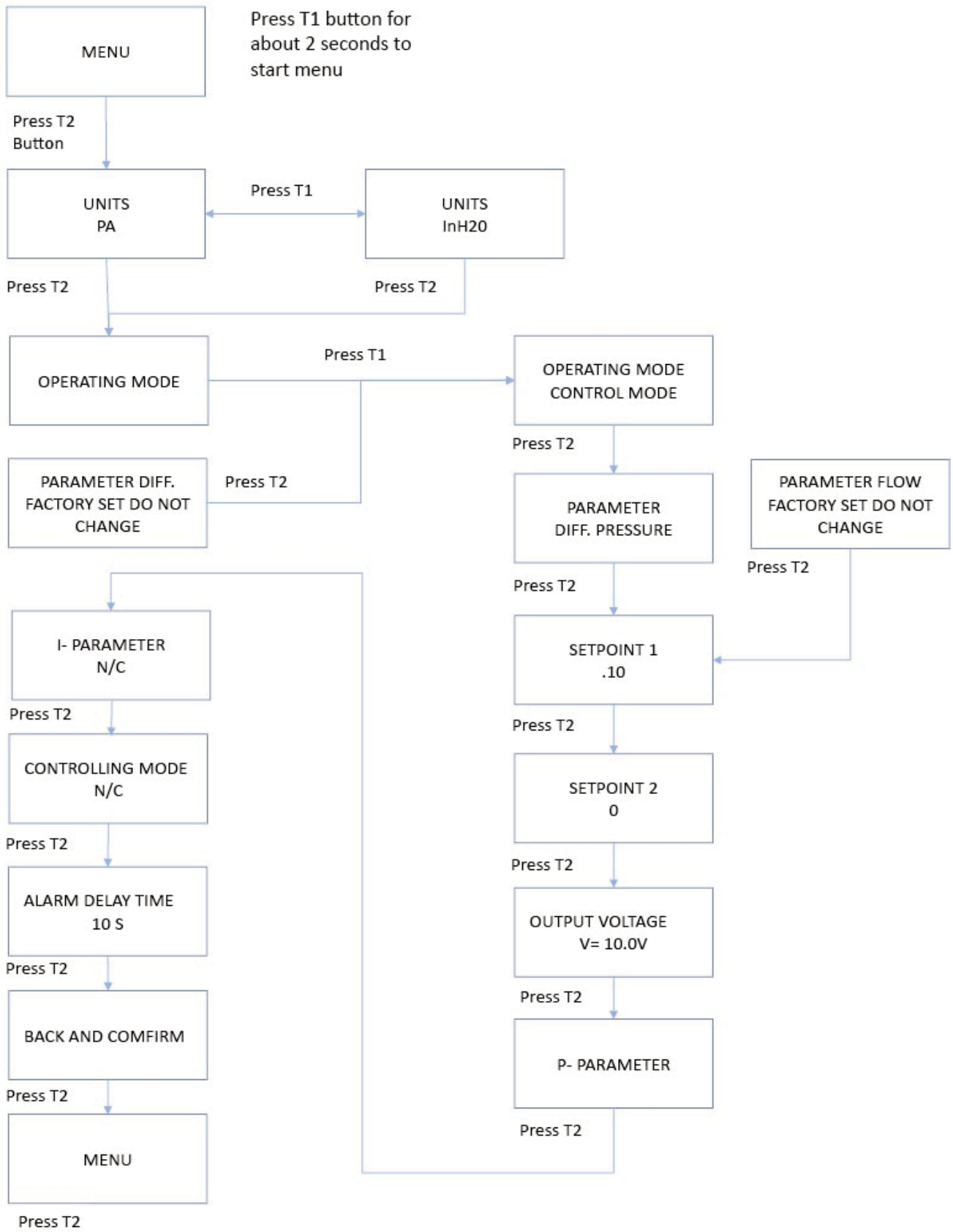

## LIMITED PARTS WARRANTY AND CLAIM PROCEDURE

1. If you have any questions about the MPC1 Controller or if it requires adjustment or repair, contact your installer, contractor or service agency.
2. If you require technical information contact Tjernlund Products, Inc. at 1-800-255-4208 with the following information.
  - Model of the Exhaust/Supply Air Fan that MPC1 is controlling as shown on the Fan nameplate.
  - Name and telephone number of installer and any service agency who performed work on the system.
  - Date of original installation and dates any service work was performed.
  - Details of the problem as you can best describe them.

Tjernlund Products, Inc. warrants the components of the MPC1 for one year from date of installation. This warranty covers defects in material and workmanship. This warranty does not cover normal maintenance, transportation or installation charges for replacement parts or any other service calls or repairs. This warranty DOES NOT cover the complete MPC1 if it is operative, except for the defective part.

Tjernlund Products, Inc. will issue credit or provide a free part to replace one that becomes defective during the one year warranty period. Proof of date of the installation in the form of the contractor sales/installation receipt is necessary to prove the unit has been in service for under one year. All receipts should include the date code of the MPC1 to ensure that the defective component corresponds with the complete unit. This will help prevent possible credit refusal.

After the faulty component is determined, return it to your Tjernlund distributor for replacement. Please include MPC1 date code component was taken from. The date code is located inside the MPC1 enclosure. The first two digits are the day, second two digits the month and third two digits are the year of manufacture. The last two digits are the Tjernlund manufacturing order number. If the date code is older than one year, you will need to provide a copy of the original installation receipt to your distributor. Credit or replacement will only be issued to a Tjernlund distributor after the part has been returned prepaid to Tjernlund and verified defective.

## WHAT IS NOT COVERED

- Product installed contrary to our installation instructions, altered, neglected or misused
- Product that has been wired incorrectly
- Any freight charges related to the return of the defective part
- Any labor charges related to evaluating and replacing the defective part

## REPLACEMENT PARTS

<u>Component</u>	<u>Part Number</u>
Pressure Control	950-9355
Alarm & Safety Circuit Relays	950-1040
Pressure Switch	PSA-1
Integral UC1 Burner Interlock Control*	950-8804

\*NOTE: The 950-8804 is Tjernlund's standard UC1 Control Board

### TJERNLUND LIMITED ONE YEAR WARRANTY

Tjernlund Products, Inc. warrants to the original purchaser of this product that the product will be free from defects due to faulty material or workmanship for a period of (1) year from the date of original purchase or delivery to the original purchaser, whichever is earlier. Remedies under this warranty are limited to repairing or replacing, at our option, any product which shall, within the above stated warranty period, be returned to Tjernlund Products, Inc. at the address listed below, postage prepaid. THERE ARE NO WARRANTIES WHICH EXTEND BEYOND THE DESCRIPTION ON THE FACE HEREOF, AND TJERNLUND PRODUCTS, INC. EXPRESSLY DISCLAIMS LIABILITY FOR INCIDENTAL OR CONSEQUENTIAL DAMAGES ARISING FROM THE USE OF THIS PRODUCT. THIS WARRANTY IS IN LIEU OF ALL OTHER EXPRESS WARRANTIES AND NO AGENT IS AUTHORIZED TO ASSUME FOR US ANY LIABILITY ADDITIONAL TO THOSE SET FORTH IN THIS LIMITED WARRANTY. IMPLIED WARRANTIES ARE LIMITED TO THE STATED DURATION OF THIS LIMITED WARRANTY. Some states do not allow limitation on how long an implied warranty lasts, so that limitation may not apply to you. In addition, some states do not allow the exclusion or limitation of incidental or consequential damages, so that above limitation or exclusion may not apply to you. This warranty gives you specific legal rights and you may also have other rights which may vary from State to State. Send all inquiries regarding warranty work to Tjernlund Products, Inc. 1601 9th Street, White Bear Lake, MN 55110-6794. Phone (651) 426-2993 • (800) 255-4208 • Fax (651) 426-9547 • Email fanmail@tjfans.com.